

Concepts for Behind-the-Meter Net Generation

Pradip Ganesan

Donna Pratt

New York Independent System Operator

**Joint Meeting of Installed Capacity, Market Issues
and Price Responsive Load Working Groups**

September 4, 2015

NYISO, Rensselaer, NY

Topics

- ◆ **Background**
- ◆ **Concepts for Energy Market Participation**
- ◆ **Concepts for Capacity Market Participation**
- ◆ **Tentative Project Timeline**
- ◆ **Next Steps**

BTM:NG Resource Definition

- ◆ **A BTM:NG resource is a facility that has on-site generation capability that routinely serves its host Load and has excess generation capability after serving that host Load**
- ◆ **NYISO proposes to allow BTM:NG resources to participate in:**
 - ***Energy Market***
 - ***Capacity Market***
 - ***Ancillary Services Market***

General Eligibility Requirements for BTM:NG Resources

- ◆ **Meet NYSDEC requirements to operate under non-emergency conditions**
- ◆ **Have an effective interconnection agreement**
- ◆ **Meet minimum net generation requirements**
- ◆ **Have appropriate metering configurations**

Concepts for Energy Market Participation

Topics for BTM:NG Resource Energy Market Concepts

- ◆ **Review Participation requirements for BTM:NG Resources**
 - *Minimum Load Requirements*
 - *Minimum Generation Requirements*
 - *Minimum Net Generation Requirements*
 - *Telemetry & Metering Requirements*
- ◆ **Review of different BTM:NG Configurations**
 - *Review of ancillary services that can be offered in different bid modes*
- ◆ **Treatment of BTM:NG Resources**
 - *UOL*
 - *Start Up/Min Gen Costs*
 - *Min Gen MWs*
 - *Incremental Cost Curves*
 - *Required Offer Parameters*
- ◆ **Review Settlement Process**
- ◆ **Review Outage Scheduling Process**
- ◆ **Review Energy Market Mitigation**

Participation Requirements

Minimum Host Load

- ◆ **To qualify as a BTM:NG resource, a minimum of 1 MW of Average Coincident Host Load (“ACHL”) will be required**
 - *The ACHL is the Average of the host load’s top 20 Load hours coincident with the top 40 NYCA Peak Load hours of the Prior Capability Year*
 - *This evaluation will be performed annually*
- ◆ **An estimated ACHL can be used for the first year of participation**
- ◆ **Host Load includes all electrically connected loads within the defined electrical boundary served by the on-site generation**
 - *This includes station power*
 - *A generator with no host load other than station power does not qualify to participate as a BTM:NG resource*

Participation Requirements (cont'd)

Minimum Generation

- ◆ The behind-the-meter generator must have a nameplate rating of greater than 2 MW
 - *BTM:NG resources will be required to report GADS data, as required by the ICAP Manual*
- ◆ A design for participation of smaller generators may be considered after the initial phase is deployed or in a different project for integration of Distributed Energy Resources

Participation Requirements (cont'd)

Minimum Net Generation

- ◆ A BTM:NG resource must be large enough to export (inject to the grid) at least 1 MW in the energy market after serving its host load
- ◆ The interconnection must also allow an export (injection to the grid) of at least 1 MW
 - *Multiple injection points at lower voltages may be acceptable provided they aggregate to a single injection into the New York State Transmission System*
 - *The ISO shall review and approve each plant configuration for facilities seeking to participate as a BTM:NG resource*
- ◆ A BTM:NG resource may aggregate generation resources at the facility in order to inject at least 1 MW in the energy market provided the generation and host load are electrically connected behind the facility interconnection point(s)

Participation Requirements (cont'd)

Telemetry & Metering Requirements

- ◆ Each BTM:NG resource must have a TO net meter at each interconnection point from the BTM:NG resource to the distribution or transmission system
- ◆ The TO net meter will be used to determine the energy injected into the grid by the BTM:NG resource and needs to be revenue grade quality
 - *The TO net meter will be used in settlements to calculate payments to the BTM:NG resource for injecting energy into the grid*
- ◆ Gross generator meter(s) and a facility net meter or gross load meter(s) will be used for qualification and verification purposes and to provide redundancy for the TO net meter

BTM:NG Configurations

- ◆ **The BTM:NG resource must be able to follow dispatch instructions from NYISO via the connecting TO**
 - *Direct communication with the NYISO is permitted as a secondary communication path.*
- ◆ **Participation at a facility will be either:**
 - *As a single generator serving a host load (Option 1);*
 - *As an aggregated set of generators serving a host load (Option 2)*

BTM:NG Metering Configuration – Option 1

Single generator serving host load
 - Facility must have meters in row 1 or row 2

Gross Generation Meter	Gross Load Meter	Facility Net Meter	TO Net Meter
✓	✓		✓
✓		✓	✓

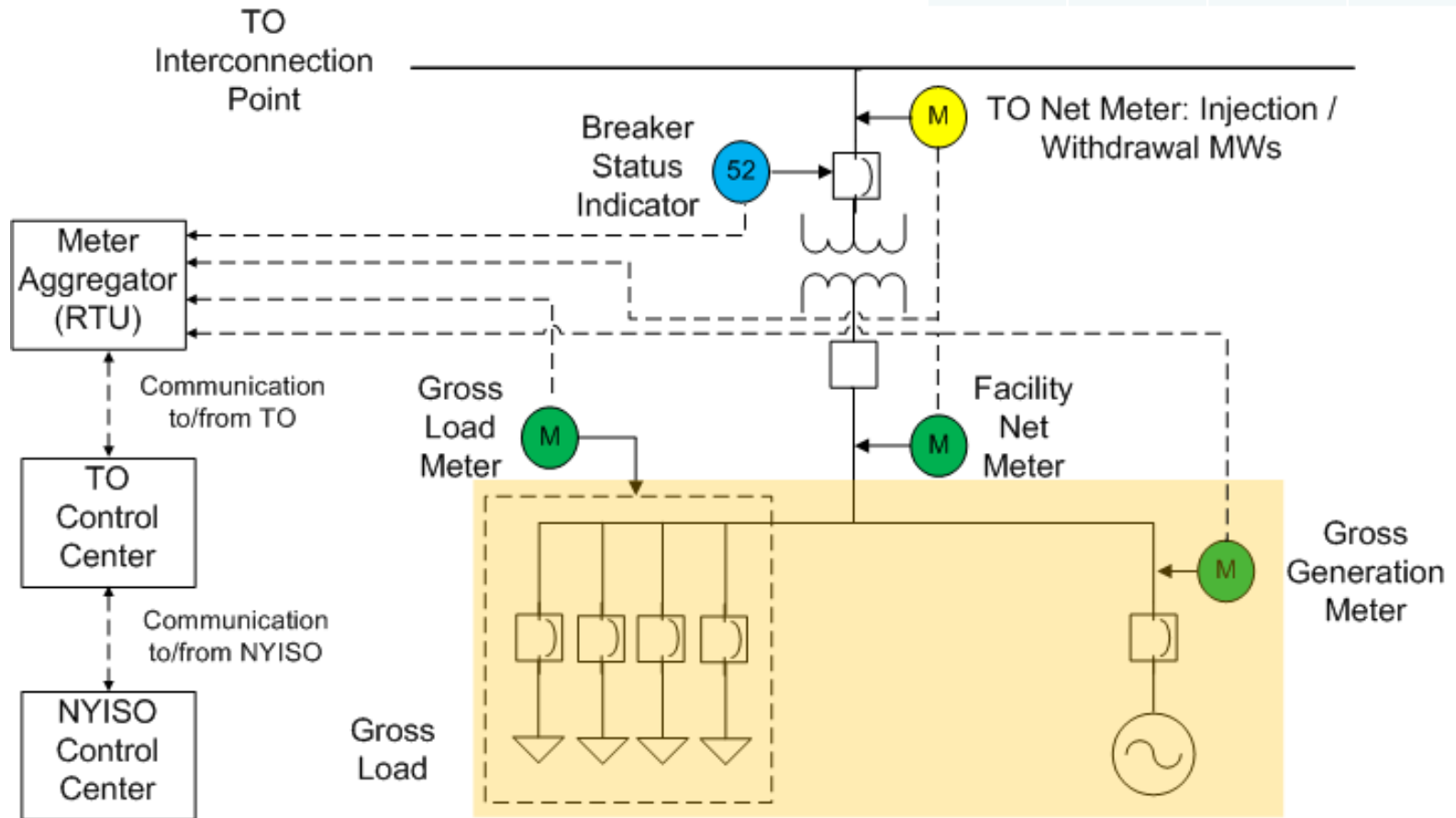

BTM:NG Resource Market Participation Review – Option 1

Single resource serving host load (Configuration Option 1)	Energy	Regulation	10-Min Spin	10-Min Non-Spin	30-Min Reserve
Self-Scheduled Fixed	✓	✗	✗	✗	✗
Self-Scheduled Flexible	✓	✓	✓	✓	✓
ISO-Committed Fixed	✓	✗	✗	✗	✗
ISO-Committed Flexible	✓	✓	✓	✓	✓

BTM:NG Metering Configuration – Option 2

Aggregated set of generators
Serving host load

- Facility must have meters in row 1 or row 2

Aggregated Meter or Individual Generation Meters	Gross Load Meter	Facility Net Meter	TO Net Meter
✓	✓		✓
✓		✓	✓

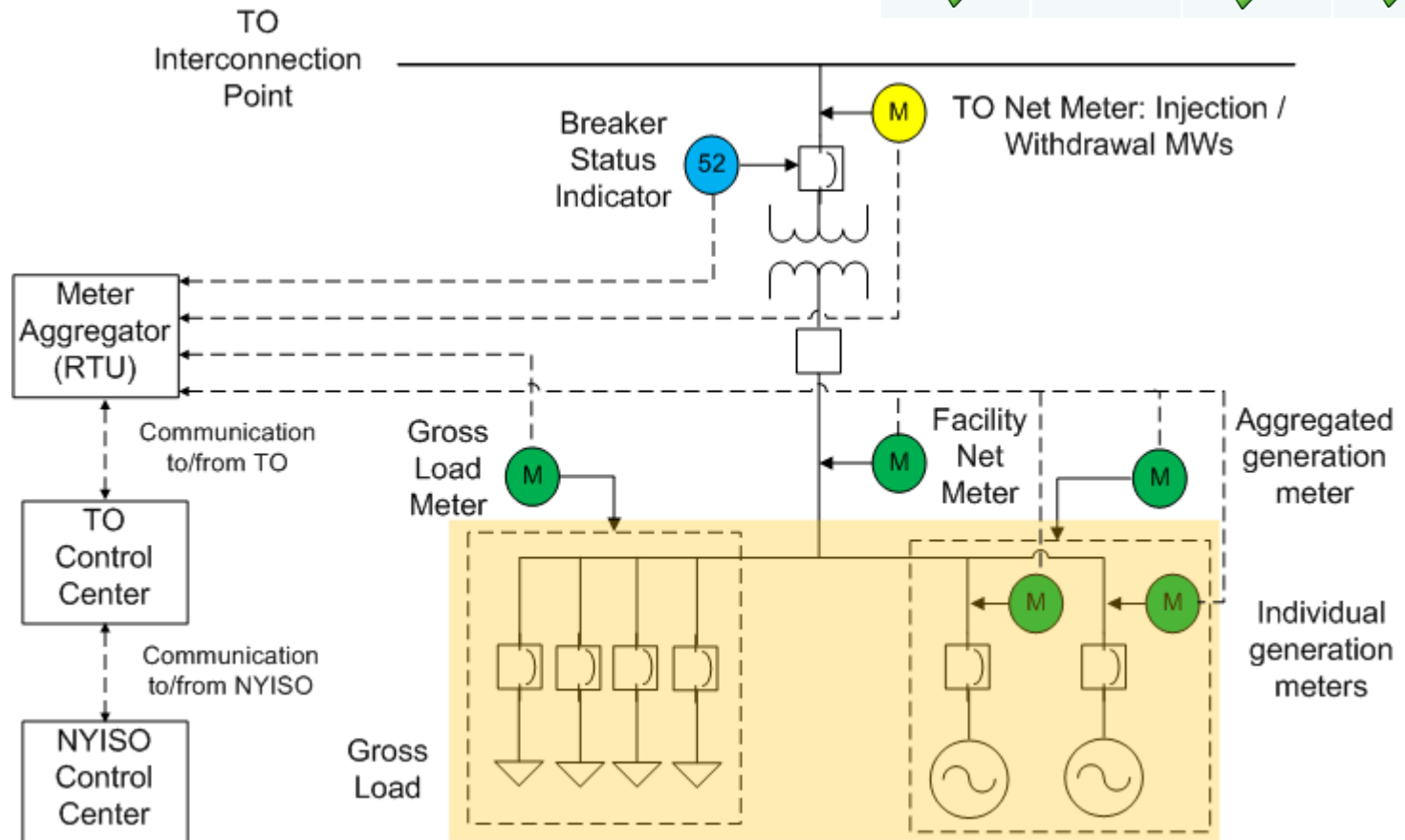

BTM:NG Resource Market Participation Review – Option 2

Aggregated resource serving host load (Configuration Option 2)	Energy	Regulation*	10-Min Spin*	10-Min Non-Spin	30-Min Reserve
Self-Scheduled Fixed	✓	✗	✗	✗	✗
Self-Scheduled Flexible	✓	✗	✗	✓	✓
ISO-Committed Fixed	✓	✗	✗	✗	✗
ISO-Committed Flexible	✓	✗	✗	✓	✓

* Not allowed because NYISO has no visibility of the individual units to confirm that the product is being provided by a synchronous resource

Treatment of BTM:NG Resources in the Energy Markets – UOL

- ◆ The NYISO’s proposed market design will utilize the unit’s available net generation. The market model will treat the net generation as available energy from the BTM:NG resource. For flexibly bid BTM:NG resources, net generation will be their dispatchable range.
 - *The BTM:NG resource will enter the Normal UOL and the host load it expects to serve for each hour with its energy offer*
 - *The Normal UOL for a BTM:NG resource is its net injection capability into the grid after serving its host load*
 - BTM:NG resource shall adjust its Normal UOL to reflect its injection limit, as necessary

Treatment of BTM:NG Resources in the Energy Markets – Start Up/Min Gen Costs

- ◆ The NYISO has determined that start-up and minimum generation guarantees will not be available for BTM:NG resources
 - *The primary function of a BTM:NG resource is to serve its host load before injecting into the grid, not to make its generation capacity available to the electric grid whenever it is economic*
 - *In addition, the dispatch system does not have sufficient visibility of individual BTM:NG resource(s) to determine whether, when scheduled, the BTM:NG resource has to start up to provide energy to the grid*

Treatment of BTM:NG Resources in the Energy Markets – Min Gen MWs

- ◆ The minimum generation MWs (Min Gen MWs) for a BTM:NG resource will be set to zero
 - *Dispatch decisions for BTM:NG resources will be based on incremental cost curves*
 - *The need for a BTM:NG resource to serve its host load stands in place of the minimum generation level needed to serve the grid*
 - *The BTM:NG resource's net generation will be treated as available between zero and the Normal UOL submitted as part of its offer*
 - Again, net generation is the portion of the BTM:NG's generation beyond the generation it uses to serve its host load

Treatment of BTM:NG Resources in the Energy Markets – Incremental Cost Curves

- ◆ **Incremental cost curves for the entire range of the BTM:NG unit’s output, including the output needed to serve the host load, are required as part of the energy offer.**
 - *The cost curves for the entire range of generation are required to allow for proper reference level cost evaluation by Market Mitigation and Analysis.*
 - **The reference level software will be available to BTM:NG resources.**

Treatment of BTM:NG Resources in the Energy Markets – Incremental Cost Curves

The incremental cost curves for the entire range of the BTM:NG resource’s output, including the output needed to serve the host load, are required as part of the energy offer. The portion of the cost curve that represents the MWs available for dispatch between zero and the Normal UOL is depicted below.

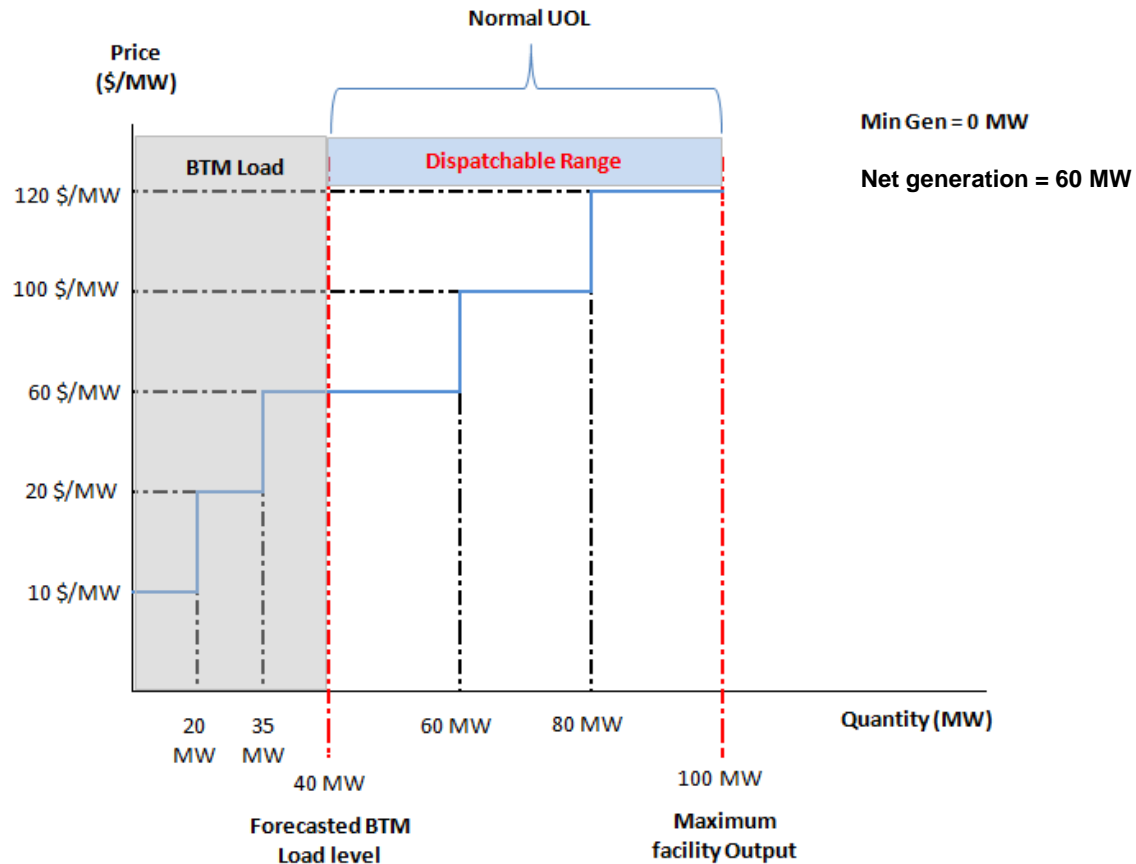

Treatment of BTM:NG Resources in the Energy Markets – Req'd. Offer Parameters

- ◆ The following parameters are required as part of the energy offer
 - *Bid Mode (ISO-Committed Flexible, ISO-Committed Fixed, Self-Committed Flexible, Self Committed Fixed)*
 - *Normal/Emergency UOL*
 - *Forecasted host load value*
 - *Incremental Cost Curves as discussed*
- ◆ Resource response rates will also be required
- ◆ A BTM:NG resource is not required to submit any commitment related parameters as part of its offer

Settlement for BTM:NG Resources

- ◆ The BTM:NG resource will be settled using the TO net meter reading at the interconnection point
 - *A net injection will receive LBMP for MW not associated with a bilateral*
 - Deviations from base points are subject to the same rules and penalties as wholesale generators
 - *A net withdrawal will be settled with the wholesale LSE, as is done today*
- ◆ The BTM:NG resource will be subject to wholesale market charges as a wholesale generator, based on its injections into the grid

Outage Scheduling Process

- ◆ **BTM:NG resources will be required to follow the same outage scheduling process as do other wholesale generators that plan to enter an outage, or cannot in real-time, meet their schedule**
 - *Please refer to the Outage Scheduling Manual for details*

Energy Market Mitigation Review

- ◆ **The BTM:NG resource's incremental cost(s) will be subject to the same mitigation measures as other wholesale generators**
- ◆ **A BTM:NG resource's forecasted host load value submitted at the time of bidding in the DA and RT markets is also subject to review and verification by MMA**
 - *The costs of energy injected by the BTM:NG resource will be the costs that appear on the incremental cost curve above that portion of the curve that represents the energy used to serve the forecasted host load value*

Concepts for Capacity Market Participation

Topics for BTM:NG Resource Capacity Market Concepts

- ◆ **Key Capacity Market Concepts for BTM:NG Resources**
 - *Net ICAP*
 - *Net UCAP*
- ◆ **Resource Availability Impacts on Net UCAP and Net ICAP**
- ◆ **CRIS Concepts**
- ◆ **Treatment of BTM:NG Resources in the IRM Study and the ICAP Load Forecast**
- ◆ **GADS Reporting**
- ◆ **Capacity Market Mitigation**
- ◆ **Shortfalls and Penalties**

Net ICAP

Net ICAP is the Installed Capacity of a BTM:NG resource that is qualified to participate in the NYISO's Capacity Market

- *Consists of a generator component and a load component*

Net ICAP Load Component

- ◆ The NYISO will annually calculate the Adjusted Host Load (AHL) of a BTM:NG resource
 - $AHL = ACHL * (1 + WNF) * (1 + RLGf) * (1 + IRM)$
 - *The AHL is calculated by adjusting the Average Coincident Host Load to account for weather normalization and Load growth, and by adding the IRM to the Load*
 - *The ACHL is a measure of the Load served by the generator in the previous Capability Year*
- ◆ The AHL accounts for the portion of the BTM:NG generator that is reserved to supply its Host Load

Net ICAP Generator Component

- ◆ The capability of the generator of a BTM:NG resource will be measured by a DMGC
- ◆ A BTM:NG resource's generation may be adjusted by the resource's injection limit or its CRIS
- ◆ Adjusted $DMGC_m$ is the BTM:NG resource's maximum generation available to the Capacity Market in a month
 - *Adj. $DMGC_m = \text{Min}(DMGC_m, AHL + \text{Injection Limit}, AHL + CRIS_{CP})$*

Net ICAP Calculation

$$\text{Net ICAP} = \text{Adj. DMGC}_m - \text{AHL}$$

Net ICAP is the Installed Capacity of a BTM:NG resource that is qualified in the NYISO's Capacity Market

Net UCAP

- ◆ **Net UCAP is the Net ICAP of a BTM:NG resource adjusted for the availability of the generator**
- ◆ **Net UCAP is the capacity of the BTM:NG resource available for sale in the NYISO's Capacity Market**

Net UCAP Concepts

- ◆ **Net UCAP will be calculated using separate derating factors - one will apply to the BTM:NG resource's generator assets and another to its Load**
 - *The derating factor for the BTM:NG resource's generator will be based on generator availability*
 - *The derating factor for the BTM:NG resource's Load will be consistent with the current derating that translates LSE Load from ICAP to UCAP*
- ◆ **Increased load will not contribute to the generator derating factor**

Net UCAP Derating Factors

- ◆ The maximum generation available to the Capacity Market (Adj. DMGC) will be adjusted by the generator's EFORD
 - *Gen Derating = (Adj. DMGC_m * (1-EFORd))*
- ◆ The Load of the BTM:NG resource will be adjusted by the Translation Factor (TF) for the applicable Capability Period
 - *Load Derating = (AHL * (1 - NYCA TF_{CP}))*

Net UCAP Calculation

Net UCAP =

$$(\text{Adj. DMGC}_m * (1 - \text{EFOR}_d)) - (\text{AHL} * (1 - \text{NYCA TF}_{\text{CP}}))$$

Net UCAP is the Unforced Capacity of a BTM:NG resource that is available for sale in the NYISO's Capacity Market

Resource Availability Impacts on Net UCAP and Net ICAP

A BTM:NG resource's Net UCAP and Net ICAP will be evaluated each Capability Period based on its annual AHL and seasonal generator test

Impact of Resource Availability on Net UCAP

- ◆ If the Net UCAP of a BTM:NG resource is negative in a Capability Period, Net UCAP will be set to zero
 - *The BTM:NG resource remains qualified to participate in NYISO's markets*
 - *The NYISO shall notify the MMU each Capability Period that a BTM:NG resource's Net UCAP is negative*
- ◆ If the calculation of Net UCAP of a BTM:NG resource exceeds its Net ICAP, the Net UCAP will be set equal to the Net ICAP

Impact of Resource Availability on Net ICAP

- ◆ If the Net ICAP of a BTM:NG resource is negative for an entire Capability Period, the BTM:NG resource is not qualified to participate in the NYISO's Capacity market as a BTM:NG resource
 - *Where applicable, the five-year CRIS set and reset period for the BTM:NG resource will terminate with the first entire Capability Period in which the Net ICAP is negative (early termination to be discussed later in this presentation)*

CRIS Concepts

Topics to be Covered in CRIS Concepts

- ◆ **How a Generator May Obtain CRIS**
- ◆ **CRIS for a BTM:NG Resource**
- ◆ **Data Required for Initial CRIS of a BTM:NG resource**
- ◆ **How CRIS levels are set for BTM:NG resources**
 - *For a BTM:NG resource that obtained CRIS through a Class Year Deliverability Study*
 - Initial CRIS
 - Final Summer CRIS
 - *For a BTM:NG resource that obtained CRIS through the existing Grandfathering rule or the proposed Transition Rule*
 - Initial CRIS
 - Final Summer CRIS
- ◆ **Early Termination of the Five-year CRIS Set and Reset Period**
 - *For a BTM:NG resource that obtained CRIS through a Class Year Deliverability Study*
 - *For a BTM:NG resource that obtained CRIS through the existing Grandfathering rule or the proposed Transition Rule*

How a Generator May Obtain CRIS

- ◆ **Grandfathered CRIS**
 - *Existing Generators that meet eligibility requirements under existing grandfathering rules outlined in Section 25.9.3.1 of the OATT can acquire CRIS through a five-year CRIS set and reset period*
- ◆ **Proposed Transition Rule**
 - *Existing BTM:NG resources and generators with non-FERC jurisdictional interconnections (post CY 2007) can acquire CRIS through a five-year CRIS set and reset period, provided they have remained in operation and have an Interconnection Agreement that has not been terminated*
- ◆ **Class Year Deliverability Study**
 - *As of a date certain, the opportunity to acquire CRIS through the current grandfathering rule or the proposed Transition Rule will end*
 - *As of that date, all Generators desiring to sell capacity in the NYISO market will be subject to a Class Year Deliverability Study including:*
 - **BTM:NG resources that did not obtain CRIS through the Grandfathering rules or through the Transition Rule**
 - **Generators with non-FERC jurisdictional interconnections**

Proposed Transition Rule

- ◆ Existing BTM:NG resources and generators with non-FERC jurisdictional interconnections, other than those that qualify for Grandfathering under the current tariff, will be permitted to acquire CRIS without being subject to Deliverability requirements subject to the following limitations:
 - *Must be “existing” and request CRIS prior to the date certain to be specified in the NYISO’s tariff filing*
 - *Consistent with originally grandfathered generators under Section 25.9.3.1 of Attachment S, “existing” shall include facilities that have completed all required interconnection studies and that have an effective interconnection agreement*
 - *Must have remained in operation and have an interconnection agreement that has not been terminated*

CRIS Requirements for Generators and BTM:NG Resources

	Existing Facilities		New Facilities and Increased CRIS >2 MW
Facilities > 2 MW	Pre-dates CY 2007	Not pre-dating CY 2007 up to date specified in NYISO filing**	After the date specified in the NYISO filing**
FERC-jurisdictional	Current GF Rules §25.9.3.1 <i>until GF rules close*</i>	Subject to CY Deliverability	Subject to CY Deliverability (no change)
Non FERC-jurisdictional	Current GF Rules §25.9.3.1 <i>until GF rules close*</i>	<i>Proposed Transition Rule*</i>	<i>Subject to CY Deliverability*</i>

* Proposed changes appear in *red*

** Date when rules subjecting new generators > 2 MW to deliverability requirements are in effect

Initial CRIS for a BTM:NG Resource

- ◆ A BTM:NG resource acquiring CRIS through the existing Grandfathering Rule, the Proposed Transition Rule, or through a CY Deliverability Study may seek CRIS up to the Net ICAP or Estimated Net ICAP value (Initial CRIS)*
 - *When meter data is available for both the Load and the generator of the BTM:NG resource, the Initial CRIS that can be requested is limited to demonstrated Net ICAP*
 - *When meter data is not available for either the Load or the generator of the BTM:NG resource, the Initial CRIS that can be requested is limited to Estimated Net ICAP*

* *For determining CRIS, Net ICAP excludes the AHL + CRIS component of the Adj. DMGC_m calculation*

Data Required for Initial CRIS for a BTM:NG Resource

◆ Load Data

- *For an existing load where appropriate metered load data is available, meter data will be used in the calculation of the ACHL*
- *For a new load or a load without appropriate metered load data, an estimated coincident Summer peak load will be used in place of the ACHL in the calculation of the AHL*
 - Documentation to support the estimated load will be required

◆ Generator Data

- *BTM:NG resources with existing generators will be required to perform a DMGC test(s)*
- *When a new generator is being installed for a BTM:NG resource, the lesser of the nameplate minus the AHL or the injection limit at the interconnection with the Transmission Owner's asset will be substituted for the DMGC*
 - A DMGC test will be required for participation in the Capacity Market

CRIS Concepts for a BTM:NG Resource that obtains CRIS through a Class Year Deliverability Study

Determination of Initial CRIS Levels for a BTM:NG Resource that Obtains CRIS through CY Deliverability Study

- ◆ The requested Initial Summer CRIS will be evaluated in the CY Deliverability Study
- ◆ Initial Summer CRIS will be the MW value determined to be deliverable, or for which the BTM:NG agreed to pay for System Deliverability Upgrades
- ◆ Initial Summer CRIS shall act as a cap through the five-year CRIS set and reset period and for the Final Summer CRIS level
- ◆ Initial Winter CRIS will equal the temperature-adjusted Initial Summer CRIS value, based on the generator's temperature curve
 - *Each year, the Winter CRIS will equal the temperature-adjusted Summer CRIS*
 - *This will limit the availability of CRIS in the winter based on generator capability during the DMGC test in the winter without regard to the size of the BTM:NG resource's Load*
 - *This maintains comparability to Winter CRIS for generators without allowing Winter CRIS to increase because the size of the load, rather than the capability of the generator itself, has changed*

Final Summer CRIS for a BTM:NG Resource that Obtained CRIS through CY Deliverability Study

- ◆ Final Summer CRIS level will be determined after a five-year CRIS set and reset period
 - *The five-year CRIS set and reset period begins with the first Summer Capability Period, following receipt of Initial CRIS, for which the BTM:NG resource's Net ICAP calculation incorporates a demonstrated ACHL*
 - A demonstrated ACHL is calculated with meter data collected from the Prior Capability Year while the associated generator participated in the NYISO's markets as a BTM:NG resource
- ◆ During the five-year CRIS set and reset period, Summer CRIS will equal the Initial Summer CRIS found deliverable in the CY Deliverability Study
- ◆ Final Summer CRIS will be the highest Summer Net ICAP value determined for any year in the five-year CRIS set and reset period
 - *Initial Summer CRIS shall not be included in the determination of Final Summer CRIS*
 - *Final Summer CRIS shall not exceed the deliverable MW of the BTM:NG resource as determined by the CY Deliverability Study*

CRIS Concepts and Examples for a BTM:NG Resource that obtains CRIS through existing Grandfathering Rule or Proposed Transition Rule

Determination of Initial CRIS Levels for a BTM:NG Resource that Obtains CRIS through Existing Grandfathering Rules or Proposed Transition Rule

- ◆ **Initial Summer CRIS will be derived from the Net ICAP or Estimated Net ICAP**
- ◆ **Initial Winter CRIS will equal the temperature-adjusted Initial Summer CRIS value, based on the generator's temperature curve**
 - *Each year, the Winter CRIS will equal the temperature-adjusted Summer CRIS*
 - *This will limit the availability of CRIS in the winter based on generator capability during the DMGC test in the winter without regard to the size of the BTM:NG resource's Load*
 - *This maintains comparability to Winter CRIS for generators without allowing Winter CRIS to increase because the size of the load, rather than the capability of the generator itself, has changed*

Final Summer CRIS Level for a BTM:NG Resource that Obtains CRIS through Existing Grandfathering Rules or Proposed Transition Rule

- ◆ Final Summer CRIS level will be determined after a five-year CRIS set and reset period
 - *The five-year CRIS set and reset period begins with the first Summer Capability Period, following receipt of Initial CRIS, for which the BTM:NG resource's Net ICAP calculation incorporates a demonstrated ACHL*
 - A demonstrated ACHL is calculated with meter data collected from the Prior Capability Year while the associated generator participated in the NYISO's markets as a BTM:NG resource
- ◆ During the five-year CRIS set and reset period, Summer CRIS will be set and reset to highest Net ICAP measured for the Summer Capability Period
- ◆ Final Summer CRIS will be the highest Summer Net ICAP value determined for any year in the five-year CRIS set and reset period
 - *Initial Summer CRIS shall not be included in the determination of Final Summer CRIS*

CRIS Concepts: Early Termination

Early Termination of the Five-Year CRIS Set and Reset Period for a BTM:NG Resource

- ◆ The five-year CRIS set and reset period shall terminate early, before the close of year five, if and when one or both of the following occur:
 - *The BTM:NG resource fails to qualify as a BTM:NG resource in the Capacity Market*
 - *The BTM:NG resource elects to participate as any other type of capacity supplier in the NYISO's markets*
- ◆ Following an early termination of the five-year CRIS set and reset period:
 - *A Final Summer CRIS value shall be determined in a manner consistent with the calculation method used for Final Summer CRIS if the full five-year period elapsed*
 - Available data from the five-year CRIS set and reset period up to the early termination will be used

Treatment of BTM:NG Resources in the IRM Study and the ICAP Load Forecast

Treatment of BTM:NG Resources in the IRM Study

- ◆ In the IRM/LCR Studies, the generation and load of BTM:NG resources will be modeled separately
 - *The generator portion of the BTM:NG resource will be evaluated for availability, as are other generators*
 - *The gross BTM:NG resource load, as determined by the Average Coincident Host Load calculation, will be added to the load forecast for the IRM/LCR studies so it will be weather normalized and evaluated for growth and load forecast uncertainty, as are all other loads*

EFORd used in the IRM Study

- ◆ An EFORd will be applied to the lesser of (i) the BTM:NG resource's DMGC or (ii) the BTM:NG resource's CRIS plus the BTM:NG resource's Adjusted Host Load
 - *The EFORd will be calculated as it is calculated for conventional generators (i.e., using GADS data)*
 - *GADS data will not include any impact from the variability of its Load*
- ◆ BTM:NG resources new to the market that have not previously reported GADS data will be assigned a NERC GADS class-average EFORd by technology type, as is currently applicable for conventional generators
 - *In the absence of the NERC class-average, the NYISO will use a zonal ICAP to UCAP translation factor*
- ◆ When a BTM:NG resource has multiple generator types behind-the-meter, the NYISO will use a blended NERC class-average EFORd for new units, or GADS data, if available, weighted by nameplate

Treatment of BTM:NG Resources in the ICAP Load Forecast

- ◆ The NYISO recognizes that the Load of the BTM:NG resource may be supplied from the distribution system from time to time (e.g., when the BTM:NG resource is not available due to maintenance or outage, or when the Load exceeds the capability or availability of the BTM:NG generation resource)
- ◆ If the Load of the BTM:NG resource is served by the distribution system coincident with the peak hour used to determine the ICAP Load Forecast, it may overstate the Load requirement of LSEs
 - *If the BTM:NG resource is a qualified Installed Capacity supplier, the Load will be subtracted from the NYCA/Locality peak Load because the BTM:NG resource is responsible for meeting the capacity requirement of its host Load*
 - *If the BTM:NG resource is not an Installed Capacity supplier, the Load of the BTM:NG resource coincident with the peak hour will continue to be included in the ICAP Load Forecast because the BTM:NG resource is not self-supplying capacity to its host Load*

GADS Reporting

GADS Data For BTM:NG Resources

- ◆ **The reporting requirements applicable to all other generators will apply to BTM:NG resources**
 - *Refer to Installed Capacity Manual, Section 4.4 and Attachment K*
- ◆ **BTM:NG resources with an aggregation of units will report GADS data as a “block” unit**
- ◆ **Host Load data will not be reported into GADS**

Capacity Market Mitigation

Supply-Side Mitigation for BTM:NG Resources

- ◆ The purpose of Supply-Side Mitigation (SSM) is to prevent physical or economic withholding by existing ICAP Suppliers that may have an incentive to raise prices
- ◆ Pivotal Supplier Measures
 - *BTM:NG resources will be subject to the spot offer price cap and Must Offer requirement for Mitigated UCAP that apply to ICAP Suppliers*
- ◆ Physical Withholding
 - *Audit and review of (i) proposals or decisions to retire, remove, or derate capacity, and (ii) reclassifications to ICAP Ineligible Forced Outages unless the unit had a Catastrophic Failure*
 - **BTM:NG resources will be subject to rules that apply to ICAP Suppliers**

Buyer-side Mitigation for BTM:NG Resources

- ◆ The purpose of Buyer-Side Mitigation (BSM) is to prevent ICAP Suppliers from artificially suppressing capacity prices due to uneconomic investment
 - *BSM will not apply to BTM:NG resources that acquire CRIS without going through a CY Deliverability Study*
 - *Mitigation Exemption Tests shall be applied to BTM:NG resources that request CRIS through a CY Deliverability Study*
 - Competitive Entry Exemption available
 - Rules to align Investment Costs and Net E&AS Revenues, i.e., to calculate Unit Net CONE

Shortfalls and Penalties

Shortfalls and Penalties

- ◆ **The capacity shortfall calculations, deficiency charges and other penalties that apply to existing generators shall apply to BTM:NG resources**

Project Timeline

Tentative Project Timeline

- ◆ **Sep. 2015 – Nov. 2015: Develop tariff language**
 - *Tariff, software, and manual changes expected*
 - *Provided project remains on schedule, including regulatory approval, implementation is expected in Q4 2016*
- ◆ **Dec. 2015: Target for BIC and MC votes on tariff language**
- ◆ **Jan. 2016: Target for Board approval and filing**
- ◆ **Feb. – May 2016: Requirements and Use Case development**
- ◆ **Apr. – Oct. 2016: Development, testing and target deployment**

Next Steps

- ◆ **September 16: Presentation to BIC for Concept Approval**
- ◆ **Proposed tariff language to be discussed over multiple meetings**

BIC Vote - Purpose

- ◆ The NYISO is scheduling a BIC vote to approve the market design concepts we have been discussing since September 2014 (Joint MIWG/ICAPWG)
- ◆ In 2014, the Board and the stakeholders asked NYISO staff to develop a market design concept for behind the meter net generators in 2015
- ◆ The 2015 Project Schedule indicates that progress on this effort is to be gauged by a “market design approved” vote
- ◆ If approved, NYISO staff will begin developing amendments to add capacity and energy market participation rules for these generators to the tariff
 - *Additional BIC and MC votes will be necessary to approve all tariff amendments*

The New York Independent System Operator (NYISO) is a not-for-profit corporation responsible for operating the state's bulk electricity grid, administering New York's competitive wholesale electricity markets, conducting comprehensive long-term planning for the state's electric power system, and advancing the technological infrastructure of the electric system serving the Empire State.

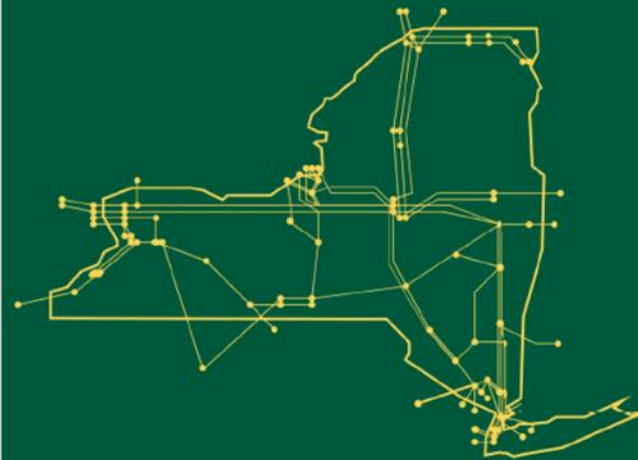

www.nyiso.com